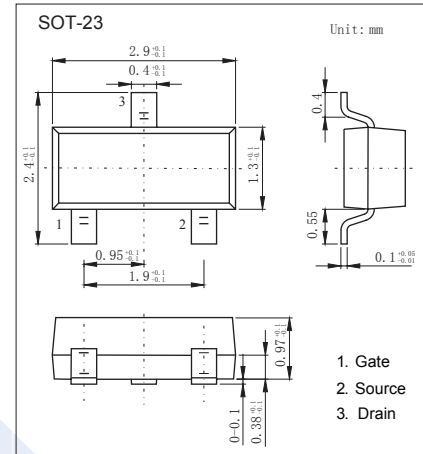

N-Channel MOSFET

IRLML0060

■ Features

- $V_{DS} (V) = 60V$
- $R_{DS(ON)} < 92m\Omega$ ($V_{GS} = 10V$)
- $R_{DS(ON)} < 116m\Omega$ ($V_{GS} = 4.5V$)

■ Absolute Maximum Ratings $T_a = 25^\circ C$

Parameter	Symbol	Rating	Unit
Drain-Source Voltage	V_{DS}	60	V
Gate-Source Voltage	V_{GS}	± 16	
Continuous Drain Current	I_D	$T_A = 25^\circ C$	A
		$T_A = 70^\circ C$	
Pulsed Drain Current	I_{DM}	11	
Power Dissipation	P_D	$T_A = 25^\circ C$	W
		$T_A = 70^\circ C$	
Thermal Resistance. Junction- to-Ambient **1	R_{thJA}	100	$^\circ C/W$
Thermal Resistance. Junction- to-Ambient ($t < 10s$)		99	
Junction Temperature	T_J	150	$^\circ C$
Storage Temperature Range	T_{stg}	-55 to 150	

*1: Surface mounted on 1 in square Cu board.

N-Channel MOSFET

IRLML0060

■ Electrical Characteristics ($T_J = 25^\circ\text{C}$ unless otherwise specified)

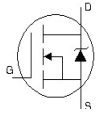
Parameter	Symbol	Test Conditions	Min	Typ	Max	Unit
Drain-Source Breakdown Voltage	V_{DS}	$I_D=250\ \mu\text{A}$, $V_{GS}=0\text{V}$	60			V
Zero Gate Voltage Drain Current	I_{DSS}	$V_{DS}=60\text{V}$, $V_{GS}=0\text{V}$			20	μA
		$V_{DS}=60\text{V}$, $V_{GS}=0\text{V}$, $T_J=125^\circ\text{C}$			250	
Gate-Body Leakage Current	I_{GSS}	$V_{DS}=0\text{V}$, $V_{GS}=\pm 16\text{V}$			± 100	nA
Gate Threshold Voltage	$V_{GS(th)}$	$V_{DS}=V_{GS}$, $I_D=25\ \mu\text{A}$	1.0		2.5	V
Static Drain-Source On-Resistance	$R_{DS(on)}$	$V_{GS}=4.5\text{V}$, $I_D=2.2\text{A}^{*2}$			116	m Ω
		$V_{GS}=10\text{V}$, $I_D=2.7\text{A}^{*2}$			92	
Forward Transconductance	g_{FS}	$V_{DS}=25\text{V}$, $I_D=2.7\text{A}$	7.6			S
Input Capacitance	C_{iss}	$V_{GS}=0\text{V}$, $V_{DS}=25\text{V}$, $f=1\text{MHz}$		290		pF
Output Capacitance	C_{oss}			37		
Reverse Transfer Capacitance	C_{rss}			21		
Gate Resistance	R_g			1.6		
Total Gate Charge	Q_g	$V_{GS}=4.5\text{V}$, $V_{DS}=30\text{V}$, $I_D=2.7\text{A}^{*2}$		2.6		nC
Gate Source Charge	Q_{gs}			0.7		
Gate Drain Charge	Q_{gd}			1.3		
Turn-On DelayTime	$t_{d(on)}$	$V_{GS}=4.5\text{V}$, $V_{DD}=30\text{V}$, $I_D = 1.0\text{A}$, $R_G=6.8\ \Omega^{*2}$		5.4		ns
Turn-On Rise Time	t_r			6.3		
Turn-Off DelayTime	$t_{d(off)}$			6.8		
Turn-Off Fall Time	t_f			4.2		
Body Diode Reverse Recovery Time	t_{rr}	$V_R = 30\text{V}$, $I_F = 1.6\text{A}$, $di/dt = 100\text{A}/\mu\text{s}^{*2}$			21	
Body Diode Reverse Recovery Charge	Q_{rr}				20	nC
Maximum Body-Diode Continuous Current	I_S	MOSFET symbol showing the integral reverse p-n junction diode. 			1.6	A
Maximum Body-Diode Pulsed Current ^{*1}	I_{SM}					
Diode Forward Voltage	V_{SD}	$I_S=2.7\text{A}$, $V_{GS}=0\text{V}^{*2}$			1.3	V

*1: Repetitive rating; pulse width limited by max. junction temperature.

*2: Pulse width $\leq 400\ \mu\text{s}$; duty cycle $\leq 2\%$.

■ Marking

Marking	1L**
---------	------

N-Channel MOSFET

IRLML0060

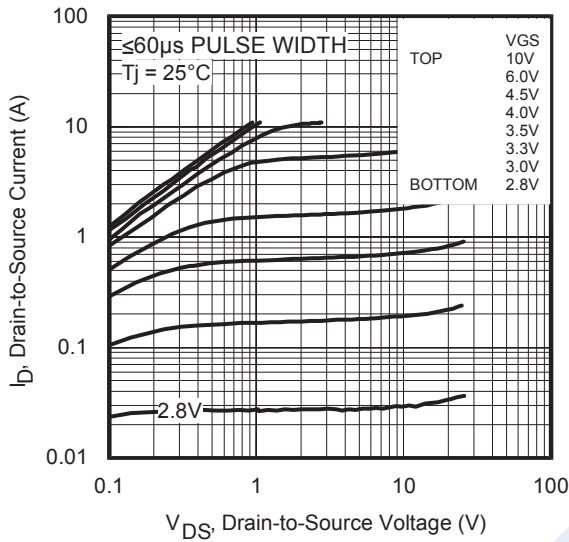

Fig 1. Typical Output Characteristics

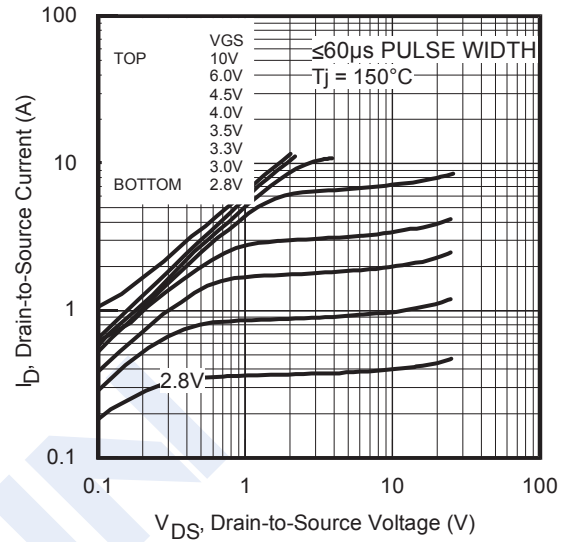

Fig 2. Typical Output Characteristics

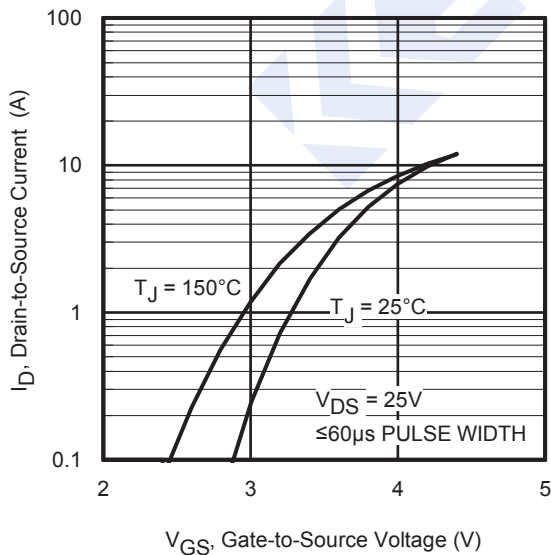

Fig 3. Typical Transfer Characteristics

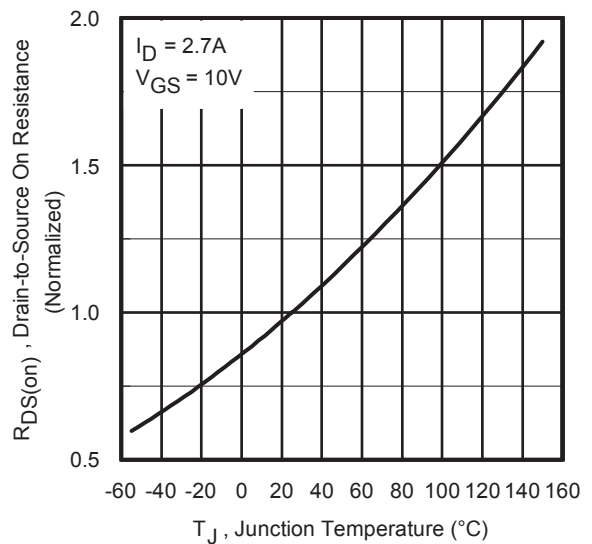

Fig 4. Normalized On-Resistance vs. Temperature

N-Channel MOSFET

IRLML0060

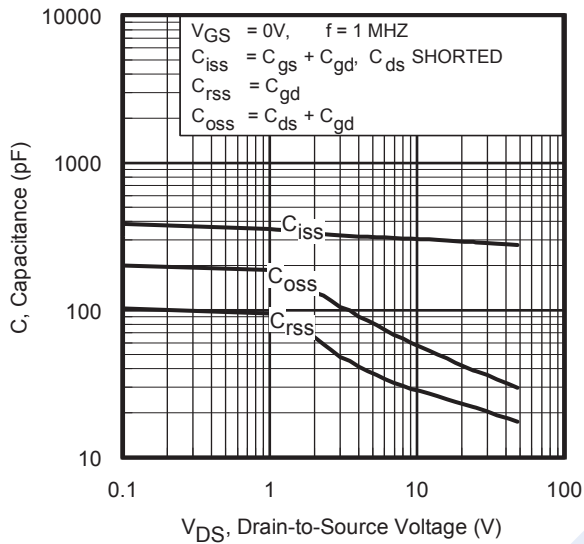

Fig 5. Typical Capacitance vs. Drain-to-Source Voltage

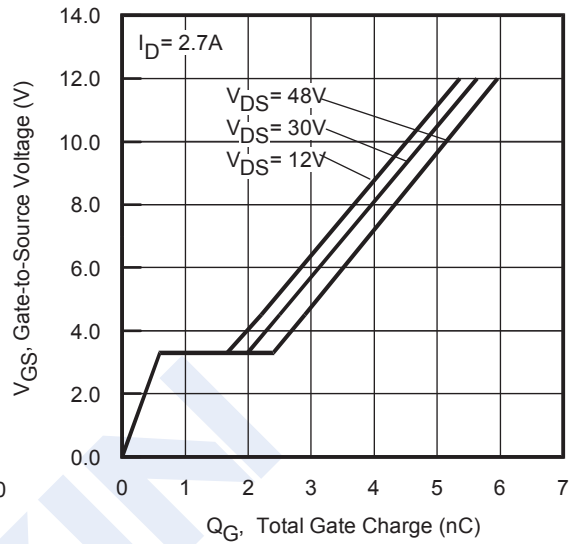

Fig 6. Typical Gate Charge vs. Gate-to-Source Voltage

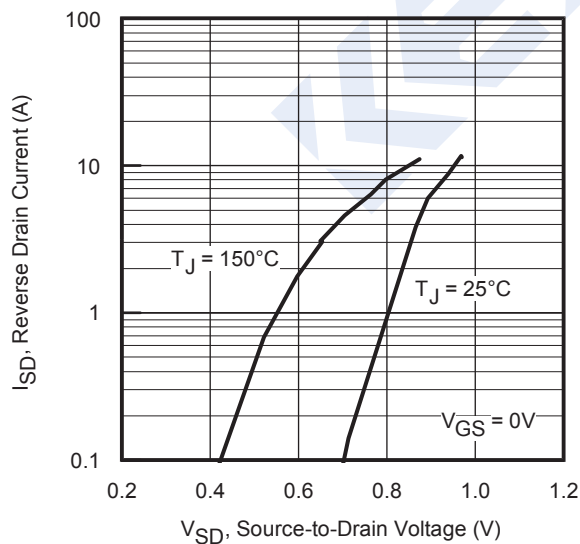

Fig 7. Typical Source-Drain Diode Forward Voltage

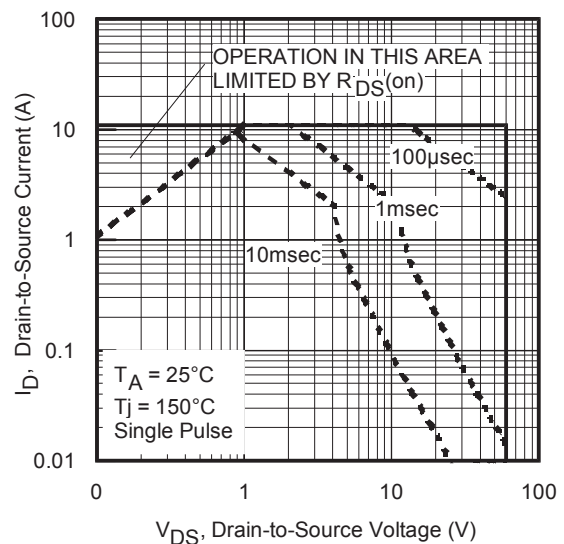

Fig 8. Maximum Safe Operating Area

N-Channel MOSFET

IRLML0060

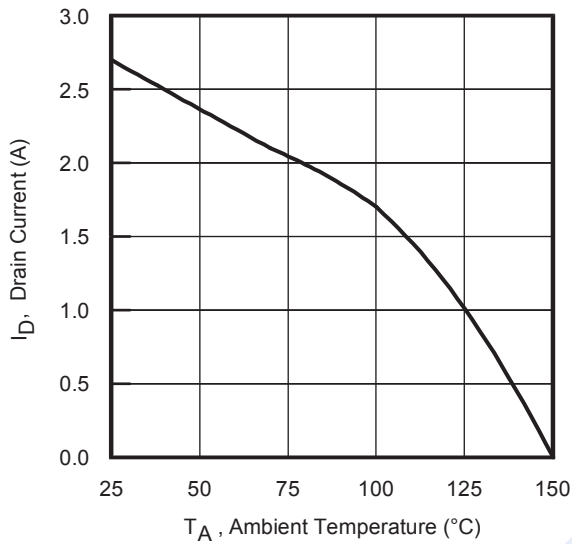

Fig 9. Maximum Drain Current vs. Ambient Temperature

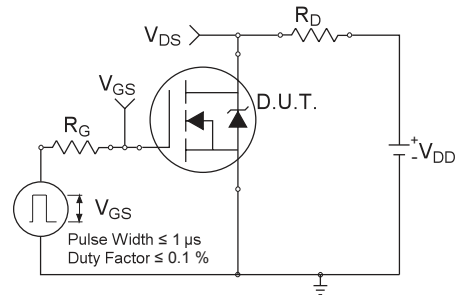

Fig 10a. Switching Time Test Circuit

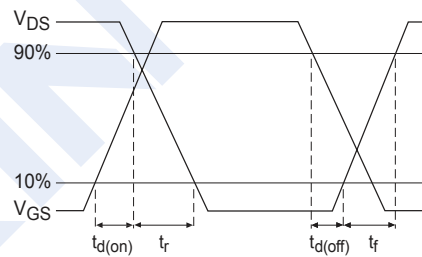

Fig 10b. Switching Time Waveforms

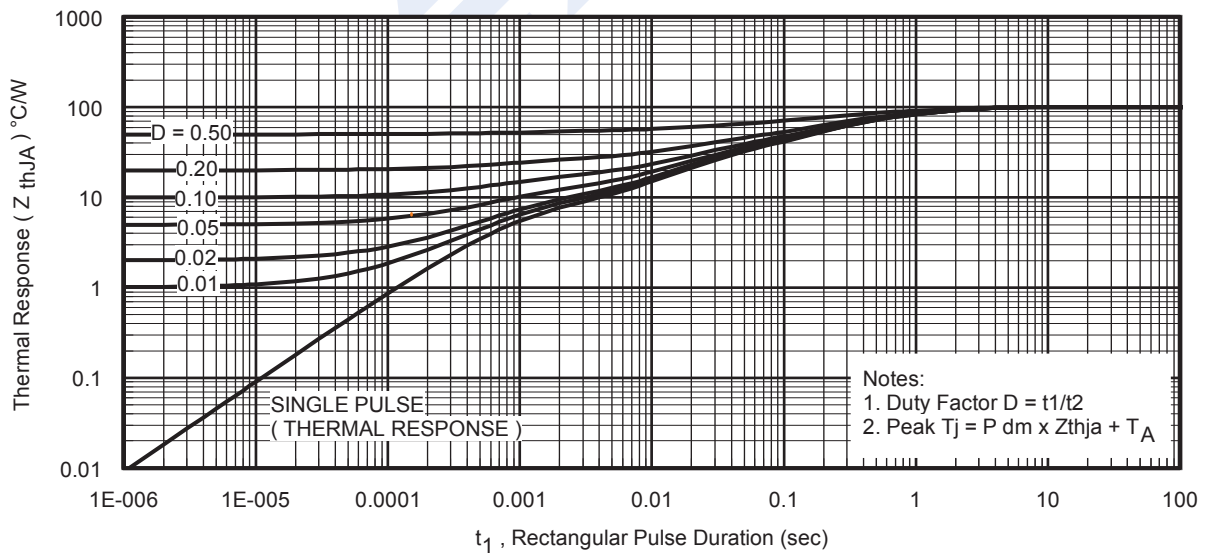

Fig 11. Typical Effective Transient Thermal Impedance, Junction-to-Ambient

N-Channel MOSFET

IRLML0060

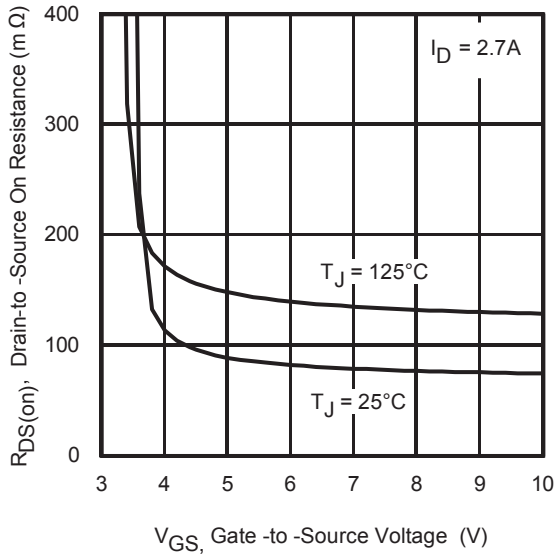

Fig 12. Typical On-Resistance vs. Gate Voltage

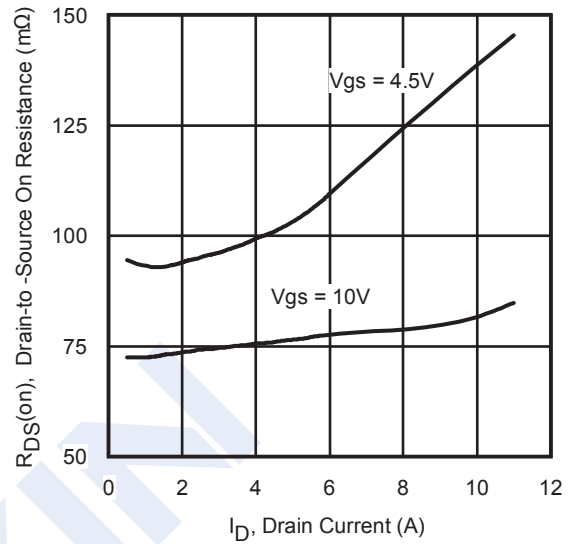

Fig 13. Typical On-Resistance vs. Drain Current

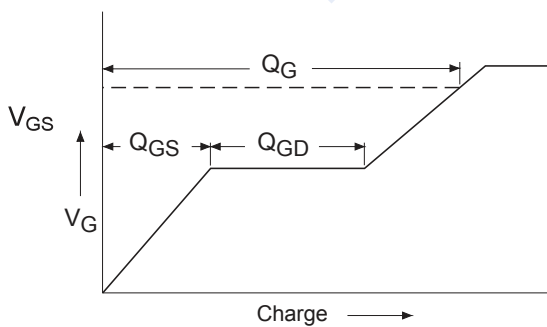

Fig 14a. Basic Gate Charge Waveform

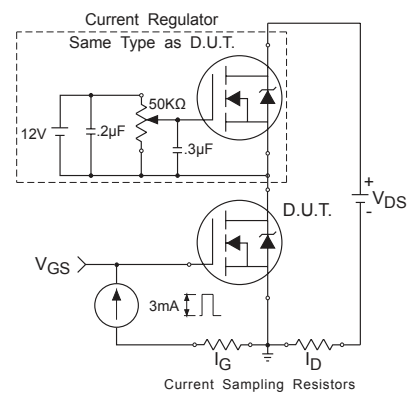

Fig 14b. Gate Charge Test Circuit

N-Channel MOSFET

IRLML0060

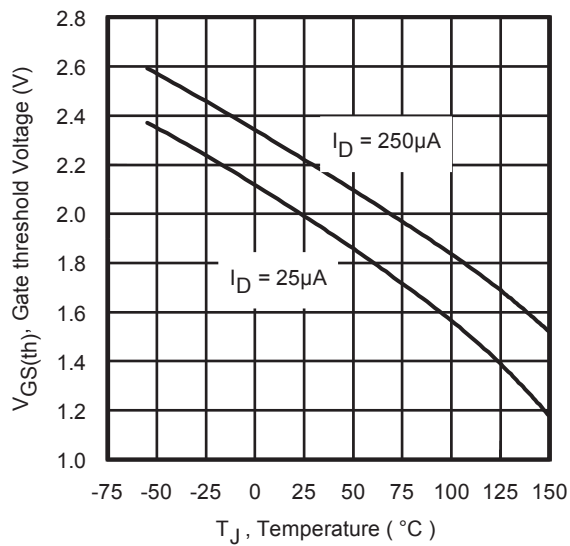

Fig 15. Typical Threshold Voltage vs. Junction Temperature

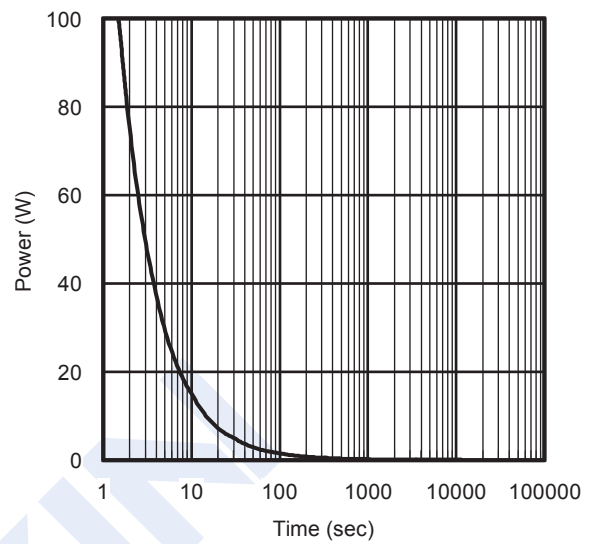

Fig 16. Typical Power vs. Time