

**isc P-Channel MOSFET Transistor**

**IRFP9140N, IIRFP9140N**

**• FEATURES**

- Static drain-source on-resistance:  
 $R_{ds(on)} \leq 0.117 \Omega$
- Enhancement mode:
- 100% avalanche tested
- Minimum Lot-to-Lot variations for robust device performance and reliable operation

**• DESCRIPTION**

- Combine with the fast switching speed and ruggedized device design, provide the designer with an extremely efficient and reliable device for use in a wide variety of applications.

**• ABSOLUTE MAXIMUM RATINGS ( $T_a=25^\circ\text{C}$ )**

SYMBOL	PARAMETER	VALUE	UNIT
$V_{DS}$	Drain-Source Voltage	-100	V
$V_{GS}$	Gate-Source Voltage	$\pm 20$	V
$I_D$	Drain Current-Continuous	-23	A
$I_{DM}$	Drain Current-Single Pulsed	-76	A
$P_D$	Total Dissipation @ $T_c=25^\circ\text{C}$	140	W
$T_j$	Max. Operating Junction Temperature	175	$^\circ\text{C}$
$T_{stg}$	Storage Temperature	-55~175	$^\circ\text{C}$

**• THERMAL CHARACTERISTICS**

SYMBOL	PARAMETER	MAX	UNIT
$R_{th(j-c)}$	Channel-to-case thermal resistance	1.1	$^\circ\text{C/W}$
$R_{th(j-a)}$	Channel-to-ambient thermal resistance	40	$^\circ\text{C/W}$

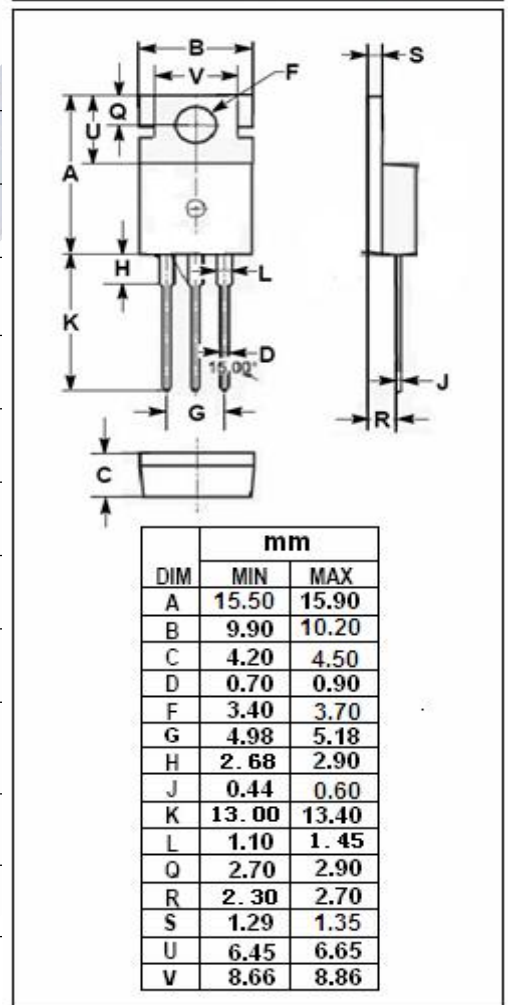
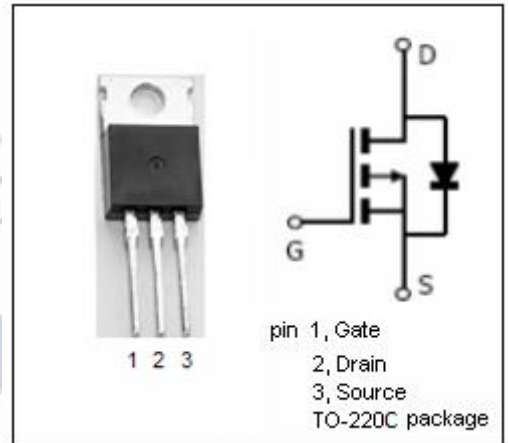

**isc P-Channel MOSFET Transistor**
**IRFP9140N, IIRFP9140N**
**ELECTRICAL CHARACTERISTICS**

 T<sub>C</sub>=25°C unless otherwise specified

SYMBOL	PARAMETER	CONDITIONS	MIN	TYP	MAX	UNIT
BV <sub>DSS</sub>	Drain-Source Breakdown Voltage	V <sub>GS</sub> =0V; I <sub>D</sub> = -250 μ A	-100			V
V <sub>GS(th)</sub>	Gate Threshold Voltage	V <sub>DS</sub> =V <sub>GS</sub> ; I <sub>D</sub> = -250 μ A	-2.0		-4.0	V
R <sub>DS(on)</sub>	Drain-Source On-Resistance	V <sub>GS</sub> = -10V; I <sub>D</sub> = -13A			0.117	Ω
I <sub>GSS</sub>	Gate-Source Leakage Current	V <sub>GS</sub> = ±20V			±100	nA
I <sub>DSS</sub>	Drain-Source Leakage Current	V <sub>DS</sub> = -100V; V <sub>GS</sub> = 0V			-25	μ A
V <sub>SD</sub>	Diode forward voltage	I <sub>F</sub> = -13A; V <sub>GS</sub> = 0V			-1.3	V